

# Kährs

QUALITY IN WOOD SINCE 1857

## INSTALLATION GUIDE

---

Kährs UK Ltd  
Unit A4 Cairo Place | Endeavour Business Park  
7 Penner Road, Havant | Hampshire | PO9 1QN  
Phone: +44 2392 453 045 | Fax: +44 2392 453 050  
E-mail: [sales@kahrs.co.uk](mailto:sales@kahrs.co.uk)

# CONTENT

## **INSTALLATION REQUIREMENTS FOR WOOD FLOORS PAGE 3**

General  
General preparations

## **INSTALLING KÄHRS WOOD FLOORS OVER UNDERFLOOR HEATING PAGE 4**

Installation

## **WHAT TO CONSIDER BEFORE INSTALLATION PAGE 5**

Scheduling installation  
Storage  
Installing boards in patterns  
Fixtures and fittings  
Planning floor installation  
Movement joints in wood floors  
Uneven subfloors  
Choice of laying direction, max. widths  
Cleaning the subfloor

## **WHAT TO CONSIDER WHEN INSTALLING PAGE 8**

Temperature and humidity conditions  
Opening packs  
Inspection  
End joints in small areas  
Gluing joints  
Pattern misalignments  
Door openings  
Fitting skirting boards  
Bowing

## **WHAT TO CONSIDER AFTER INSTALLATION PAGE 9**

Supplementary surface treatment  
Protective covering  
Tape  
Ventilation

## **INSTALLATION AND FITTING INSTRUCTIONS PAGE 10**

Installation instructions for vapour barriers and intermediate layers  
Using tools and accessories  
Installation instructions for Kährs wood floors with Woodloc® joints  
Installation instructions for Kährs Activity floor 30 mm  
Installation instructions for Kährs 15mm on 150 kPa expanded foam (domestic)  
Installation instructions for Kährs Linnea on 150 kPa expanded foam (domestic)  
Installation instructions for Kährs wood floor on 250 kPa expanded foam (public)  
Fixing instructions for wood floor accessories  
Instructions for supplementary products

## INSTALLATION REQUIREMENTS FOR WOOD FLOORS

### General

Wood is hygroscopic, ie, it is a “living” material. Depending on the ambient air humidity and temperature, the material either emits or absorbs moisture. This is associated with a change of volume (swelling or shrinkage). It is therefore important that there is an “expansion gap” or “movement joint” in between the floor and the wall and other fixed objects when a wood floor is installed floating. To stop the floor absorbing moisture prior to installation, it is important not to open packaging until just before installation.

Many mistakes and damage can be avoided by studying the installation instructions before starting installation and then following them carefully.

Note that moisture levels in new build premises often remain relatively high by the time parquet floors are installed.

To avoid damage, it is important that the relative humidity during and after installation is less than 60%. The temperature of rooms and materials must be at least 18°C. See Hus AMA98 MD. A parquet floor must not therefore be installed until all other trades, such as painters and tilers, have finished their work and the site has the correct RH.

Moisture protection is not normally necessary on structural floors where the relative humidity is below 60%. Note that newly cast structural floors do not meet this requirement, so moisture protection is always needed.

Moisture protection on the following subfloors, whatever their age, is obligatory for the reasons given above:

- concrete floor lying directly on the ground (ground-supported slab)
- floor above warm or humid area (e.g. boiler room or laundry room)
- structural floor above a ventilated crawl space foundation
- lightweight concrete floor structures
- underfloor heating

If the subfloor’s relative humidity is higher than 95%, a plastic sheeting vapour barrier will not provide sufficient moisture protection.

Wood floors should always be laid staggered, even in small areas such as halls or small rooms. Distributing the short ends evenly means that the floor will remain flat and level even during seasonal climate changes.

### General preparations

- Store the floorboards in their packaging.
- Open the packs only when needed during installation.

- Read the installation instructions carefully before installing.
- The subfloor must be dry, level, clean and solid. Remove fitted carpets. For installing on foam (EPS), download our brochure Subfloor Requirements and Underfloor Heating from our Professional Website at [www.kahrs.com](http://www.kahrs.com).
- Check that the subfloor is flat and level over measured lengths of 2 m and 0.25 m. If any unevenness exceeds  $\pm 3$  mm over 2 m or  $\pm 1.2$  mm over 0.25 m, the floor must be levelled first. (HusAMA98, Table 43.DC/-1 Class A and MDB.3). Kährs also accepts a measured length of 1 m. The tolerance in this case is  $\pm 2$  mm.
- Check the humidity of the subfloor. Subfloors consisting of newly cast concrete joists or lightweight concrete joists, ground-supported concrete floors, above warm or humid areas, over crawl space foundations or over an underfloor heating system must first have age-resistant 0.2 mm polyethene (PE) sheeting laid to protect against moisture. Lay the sheeting with a min. overlap of 200 mm. The subfloor must be cleaned thoroughly to prevent mould. If the subfloor’s relative humidity is higher than 95%, a plastic sheeting vapour barrier will not provide sufficient moisture protection.
- The room’s relative humidity must not exceed 60% RH (HusAMA98 JSF.52). The temperature of the room and the boards must reach at least 18°C.
- Where applicable, an intermediate layer can be laid on top of the sheeting to reduce impact noise. Use 2–3 mm polyethene foam of an approved quality – Kährs Tuplex or felt paper. Butt joint the edges of the intermediate layer. If an impact sound reduction rating is required, please contact an acoustics specialist.
- In narrow rooms, lay the boards in the long direction. The floor moves as the air humidity varies, and should therefore have a movement joint. For practical purposes, for floors < 6 m wide allowing a 10 mm movement joint next to walls and fixed objects (stairs, pillars, door frames, etc.) is convenient. For larger floor areas (> 6 m wide) allow 1.5 mm of movement joint per metre of floor width. This movement joint must run all round the floor. For multi-layer flooring with Woodloc®, the maximum floor width is 18 m. For Kährs Linnea, the maximum is 12 m.
- Put damaged or faulty boards to one side. They may be surplus or useful for finishing off. You can, of course, exchange any damaged boards where you purchased them.

If you make a mistake, boards with Woodloc® can be taken up and re-laid quickly and easily, which simplifies the procedure. The Woodloc® joint helps reduce mistakes during installation.

We recommend that you consult your floor supplier or ourselves about building moisture if you want to lay the floor on a construction other than those described in our brochure Subfloor Requirements and Underfloor Heating if you want to lay a large floor or if anything else is unclear.

## INSTALLING KÄHRS WOOD FLOORS OVER UNDERFLOOR HEATING

Make sure that all the necessary tests on the underfloor heating system have been completed before floor installation begins.

### Installation

The working temperature (materials, subfloor and room air) during installation must be at least 18°C. As with installation where there is no underfloor heating, the relative humidity (RH) of the air must be less than 60% before, during and after installation.

**Note that a cold subfloor warms up more slowly than the room air.**

Note that the requirement for movement joints at door openings is greater with underfloor heating because the floor moves more. Remember that a floor installed over underfloor heating is more susceptible to moisture (high RH) than an unheated floor, because the floor's moisture content varies over a wider range.

**A vapour barrier of an approved type is obligatory.**



## WHAT TO CONSIDER BEFORE INSTALLATION

### Scheduling installation

Wood floors must not be laid until all other work, e.g. painting, wall-papering and tiling, is completed. The site must have the correct RH. This avoids soiling and moisture damage to the floor.

Installing floors is easier if architraves, etc., are fitted afterwards.

### Storage

Wood flooring must be stored in an area where the RH is less than 60%. Do not open the packs of flooring until you are ready to install. Open the packs only when needed during installation.

Before installing a wood floor, ensure that the material has a minimum temperature of 18°C. It takes approximately two or three days storage in a heated site before the bundles reach the correct temperature. The temperature can be reached more quickly if the floor packs are stacked in several small piles rather than a single pile. If the protective plastic has been damaged, repair it with tape to prevent moisture damaging the contents.

### Installing boards in patterns

We recommend gluing to the substrate when the boards are to be laid in different directions in the same room. Floors with Woodloc® joints cannot be installed with ends against long sides.

### Fixtures and fittings

Fixtures and fittings, kitchen island units, partitions, etc., must never be fixed to the parquet in a floating installation. They can be fixed through the floor provided a space is allowed, to prevent the fixed object from pressing down on and trapping the parquet. There must be a movement joint around the space.

Fix all the fixtures and fittings first, and then the floor. If the wood floor must go under the fixture or fitting for any reason, there must be a movement joint under the kickboard.

Modern kitchen units are normally fixed to the wall, with supporting legs at the front resting on the floor. This is generally of no significance for the floor. However, if the worktop is made of marble, granite or another heavy material, the legs should not rest on the floor to avoid trapping it.

If the floor is glued down, fixtures and fittings can be fixed through the floor without affecting the floor's function.

If a wood-burning stove or similar is to stand on the floor, lay (e.g.) chipboard over an area slightly smaller than that of the "spark screen". This not only enables the floor to move freely but also makes it easier to replace boards near the stove if necessary. The chipboard also takes the weight of the stove. Remember to provide an expansion gap.

### Planning floor installation

Measure the width of the room, and calculate the width of the last row of boards. If it is less 30 mm, you should also cut the first row of boards so as to equalise the widths of the first and last rows. Remember to include the expansion gap.

When installing floors with Woodloc® joints, it is easier if you start on the long side with more doors. If there are doors along the short side of the room, begin each row of boards there. The boards can be installed from both left and right, as well as "backwards". If the area is geometrically complex, think carefully about the best method of installation, where you should begin laying and suitable places for expansion joints.

Plan carefully to avoid exceeding the maximum width (max 18 m for multi-layer parquet with Woodloc®, 12 m for Kährs Linnea) and to ensure adequate skirting board dimensions.

### Movement joints in wood floors

Natural seasonal variations cause a certain amount of movement (expansion and contraction) in wood floors.

This is why a floor must not be laid too close to adjacent walls or other fixed objects. In accordance with HusAMA98 MDB.3, a movement joint must be provided along each edge.

The floor must be able to expand at thresholds, door frames, heating pipes, pillars, stairs, tiled floors, other parquet flooring, etc. It is important to ensure that contraction caused by climate variations in winter will also be covered by the skirting board.

Gaps caused by contraction do not normally occur in floors with Woodloc® joints, which is why all contraction manifests itself at the outer edges.

An expansion joint (movement joint) between two rooms/floor areas can be concealed with a threshold.

**Remember that the width of the expansion joint is the sum of the widths of the movement joints for each connecting area.**

Glued floors move less than floating floors because gluing reduces movement. Movement joints 3–5 mm wide are therefore sufficient.

When wood floors are delivered their moisture content corresponds to approximately 40% RH.

The floor's RH normally varies seasonally between 30% and 60%. A wood floor must be able to move with the variation in moisture, which produces both expansion and contraction.

**The size of the movement joint in mm is calculated using the formula: 1.5 mm/metre floor width.**

A 4 m wide room should therefore have an expansion gap all round of  $4 \times 1.5 \text{ mm} = 6 \text{ mm}$  between the floor and all fixed objects. For practical reasons, allowing a 10 mm movement joint for floors less than 6 m wide is convenient.

A wood floor's movements as it absorbs and emits moisture.

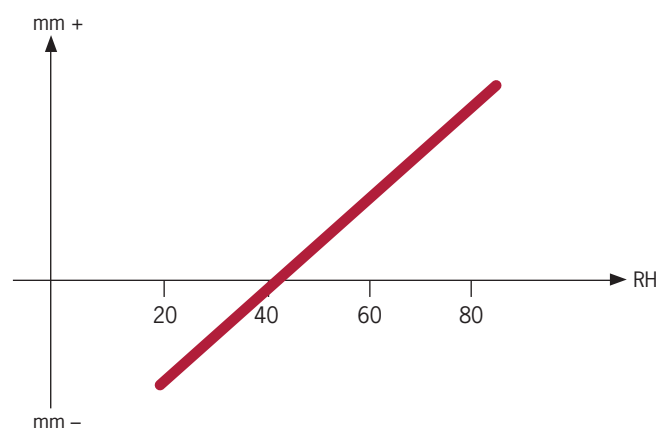

Note that the dimensions of the skirting board must never determine the size of movement joints. With large floor areas, the skirting board must therefore be selected on the basis of the required size for the expansion joint and not vice versa.

One solution for a situation that requires a large skirting board: In new buildings, a simple way of permitting additional floor movement is to “stop” wall panels immediately above the floor surface. If the wall panel is 13 mm plasterboard, for example, this provides an additional 13 mm movement allowance. This allows a thinner skirting board to be used than would otherwise be necessary.

The accessories programme includes installation wedges that are easy to use to ensure a sufficient and accurate expansion gap.

Make sure that the floor does not go under the wall panel.

Various types of mouldings are available for achieving neat junctions (see [www.kahrs.com](http://www.kahrs.com)).

### Calculate the skirting board thickness

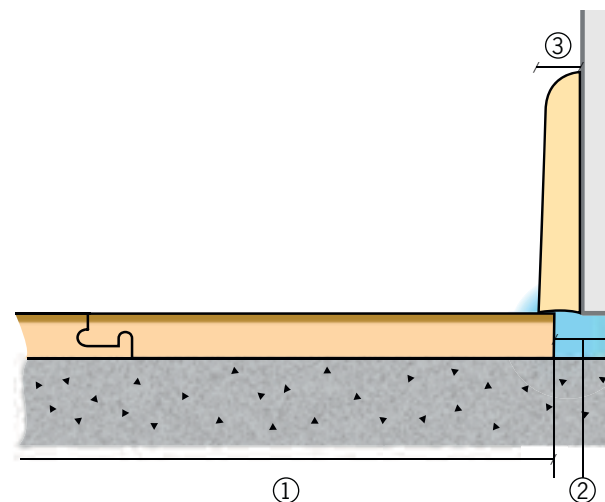
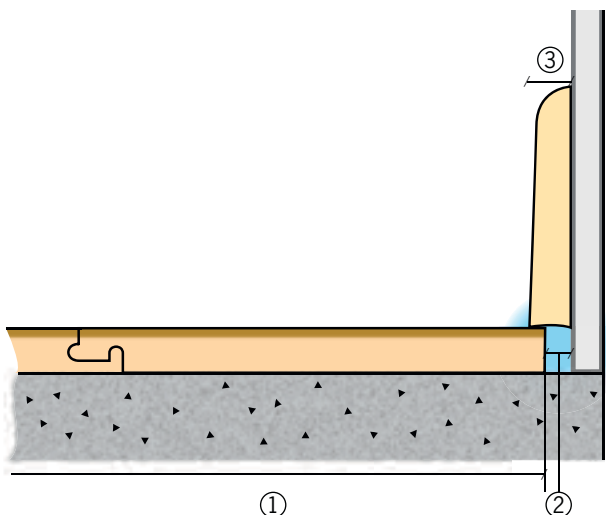

1. Floor width x 1.5 = expansion gap in mm.
2. Movement joint
3. Movement joint x 1.5 = skirting board minimum thickness in mm

Make sure that the floor does not end up under the sheet!

### Minimum skirting board thickness for various floor widths

Floor width 1	Movement joint 2	Cover allowance	Skirting thickness 3
4 m	6 mm	3 mm	15 mm*
6 m	9 mm	5 mm	15 mm*
8 m	12 mm	6 mm	18 mm
10 m	15 mm	7 mm	22 mm
12 m	18 mm	9 mm	27 mm
15 m	22 mm	11 mm	33 mm
18 m	27 mm	13 mm	40 mm

\* Because a minimum 10 mm movement joint is recommended.

**Uneven subfloors**

If small depressions in the subfloor are noticed during floating installation, they can be filled using felt paper (max. 3 layers with under-floor heating). However, do not use more than one layer of Cello-floor or similar because it is excessively soft. When gluing, never “fill” any unevenness with thick layers of glue.

**Choice of laying direction, max. widths**

We recommend laying lengthways because boards move less along their length than across their width. In narrow areas, such as halls, it is particularly important that the boards lie flat against the subfloor.

Laying diagonally is more time-consuming but can be very eye-catching. See the diagram, which shows maximum room widths when using the various flooring options.

Remember that the maximum width (at right angles to the boards) must not be exceeded (max 18 m for multi-layer parquet with Woodloc®, 12 m for Kährs Linnea, see Fig. 1). If the floor is wider than this, it must be divided (expansion joint). Take into account that the wastage will be a little higher (8–10%). Particular consideration must be given if the room does not have a simple geometric shape.

When gluing down, the laying direction does not matter because the adhesive reduces the movement of the boards. Glued floors can be wider than floating floors, subject to the subfloor requirements.

**Figure 1.** Maximum room width: 18 m multi-layer parquet with Woodloc® 12 m Linnea

**Figure 2.** Maximum room width: 12.5 m multi-layer parquet with Woodloc® 8.5 m Linnea

**Figure 3.** Maximum room width: 10.8 m multi-layer parquet with Woodloc® 7.2 m Linnea

**Figure 4.** Maximum room width: 14.5 m multi-layer parquet with Woodloc® 9.6 m Linnea

**Cleaning the subfloor**

Never leave sawdust or other organic residues on the subfloor. There is a high risk of mould growing in the damp environment that develops when a vapour barrier is laid over the organic materials, although the barrier is a requirement.

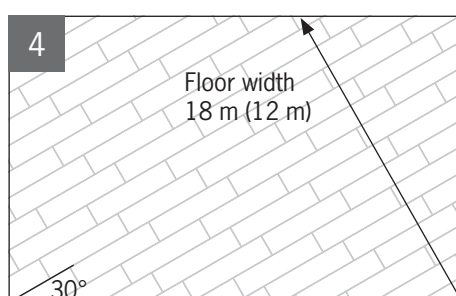
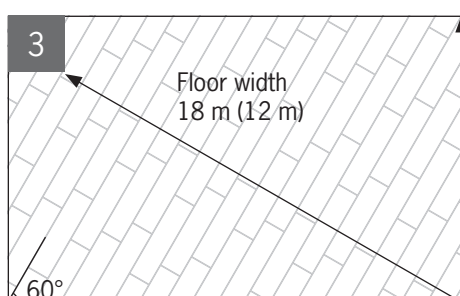
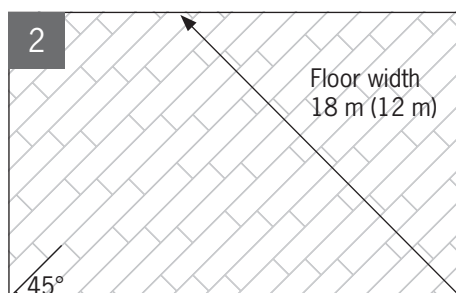
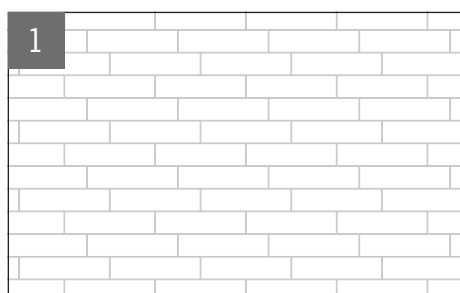

## WHAT TO CONSIDER WHEN INSTALLING

### Temperature and humidity conditions

The working temperature when laying should be at least 18°C. This applies both to the boards and to the room air. The relative humidity of the air must be less than 60% before, during and after installation.

### Opening packs

The wood floor is supplied “furniture dry”. If packs are opened too early, the boards can absorb moisture and expand, which makes them difficult to fit together. If packs have been opened, they must be resealed carefully with tape to stop moisture getting in and adversely affecting the boards.

### Inspection

It is always easier to rectify faults if they are discovered early. Always make a habit of inspecting the product at the time of installation. Faulty products can, of course, be exchanged with your supplier or ourselves. Boards with obvious faults that are or should be detectable before installation must not be used. Always make sure that inspection and installation are carried out in good light. *Figure 1.*

### End joints in small areas

Even small areas must be laid staggered, i.e. all floor areas must have end joints. The end joints of adjoining rows must be staggered by at least 500 mm (at least 300 mm for 1.2 m boards) to ensure that the floor remains flat and level during climatic variations. Otherwise there is a risk that the floor could bow in high relative humidity. Whenever the floor is glued down, the end joints should be staggered because this levels out the floor and avoids bond failure when the adhesive dries. *Figure 2.*



### Gluing joints

Adhesive should not normally be used on boards with Woodloc® joints. However, installation is sometimes easier if 1/3 of the locking edge is planed off and adhesive is applied to the horizontal underlip (see illustration). This means the board can be tapped into place. The joint will be sufficiently strong because of the wide area of adhesive. *Figure 3.*

### Pattern misalignments

Minor pattern misalignments that occur during manufacturing are permitted in accordance with HusAMA. Pattern misalignment may occur with some floors such as those from the Marina Collection, Dutch pattern and European Renaissance Collection. When laying boards with the Dutch pattern, the transverse strip must fit in the centre of the longitudinal strip on the adjoining row of boards.

### Door openings

Floors installed through door openings or archways must be divided with an expansion gap which is then covered by a threshold or moulding. If an existing threshold is fixed to the subfloor, there must be a movement joint, of the same dimension as the other movement joints in the room, between the wood floor and the threshold. Note that in accordance with RA98, there is a greater requirement for an expansion joint in door openings where underfloor heating is fitted. The threshold can also be removed, then refitted when the floor has been laid with a joint under the threshold's position. If the threshold is too high, the door can be trimmed accordingly. Cutting the door is easier if you mark the cut line with tape and use a fine-toothed saw. *Figure 4.*

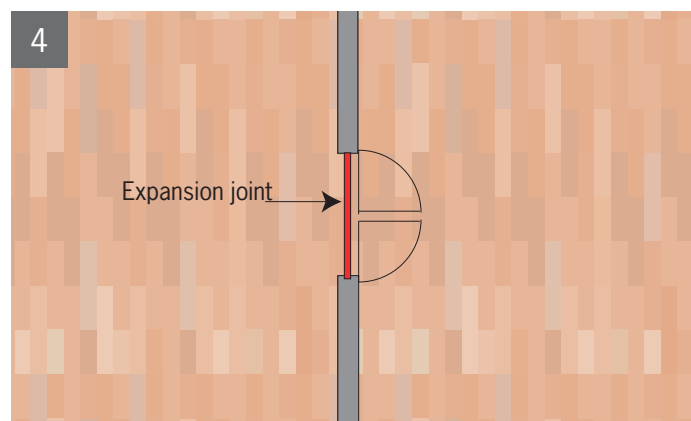
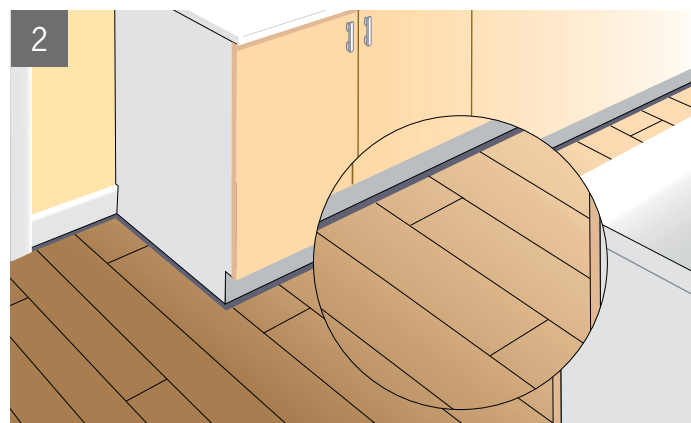

**Fitting skirting boards**

The skirting boards must not press down on the wood floor, as this may trap it. Skirting boards can be fixed to walls using nails, screws or adhesive. Best results are achieved if the joints are mitred. Skirting boards must be adapted to suit the size of the movement joint.

**Bowing**

We aim to manufacture boards that are slightly convex lengthwise to make the floor easy to lay. A board that bows up to 20 mm can be installed without it affecting the finished floor. Do not forget to stagger the end joints in accordance with the installation instructions.

**WHAT TO CONSIDER AFTER INSTALLATION****Supplementary surface treatment**

Spilt liquids must be wiped up immediately. This is particularly important for Beech and Hard Maple, because they move more than other species because of their greater sensitivity to moisture.

Normally, no supplementary surface treatment is required. However, additional surface treatment can be justified in areas where it is likely that spilt liquid will be left on the floor, to prevent discoloration and moisture damage to boards or joints.

For supplementary surface treatment on lacquered floors, use Kährs Lacquer or similar. On UV-oiled floors, use Kährs UV/Nature Oil Refresher. For floors with nature oil finish, use Watco Satin Oil.

Note that re-lacquering produces a more “plastic” surface than a factory-lacquered floor, and that scratches are more visible because scratch-resistance is somewhat lower. Re-lacquering is not carried out in a dust-free environment, so there is a risk that dust particles will adhere to the surface and form little bumps that are visible when the lacquer dries.

Stained products should be given supplementary treatment if wear is expected to be greater than is normal in domestic applications.

**Protective covering**

If further work is to be carried out in the room where the floor has been installed, the floor must be protected with a moisture permeable material (e.g. paper). Check that this will not discolour the floor. Note that some commonly used types of papers do not allow moisture to pass through, and have a wax coating that may be transferred to the wood floor. This causes undesirable gloss variations.

White goods do not usually have sufficiently large “wheels” to avoid causing damage if they are moved across the floor, in which case the floor requires much greater protection than protective paper alone.

**Tape**

Tape only to the protective covering, not to the wood floor. Many types of tapes stick to the floor so firmly that they lift the lacquer when removed. The longer the tape is left in place, the greater the risk of it adhering too strongly to the lacquer.

**Ventilation**

When a floor is installed in a new building, ensure adequate ventilation to prevent building moisture damaging the floor. If the RH is higher than 60% there can be permanent deformation due, for example, to cellular collapse and/or laminate penetration.

## INSTALLATION AND FITTING INSTRUCTIONS

### Installation instructions for vapour barriers and intermediate layers

**1.** Plastic sheeting, 0.2 mm age-resistant polyethene sheeting, is used as a vapour barrier and must be laid with an overlap of at least 200 mm. It is supplied folded double. The plastic sheeting must be as close to the parquet as possible in the construction but beneath the intermediate layer. When installing with EPS, the vapour barrier must be placed under the insulation in accordance with RA 98Hus, JFS.52. Avoid walking on plastic sheeting once it has been laid.

Remember that organic material goes mouldy in a humid environment.

**2.** Felt paper (1 mm intermediate layer) must be laid with butt-jointed edges and must always be laid above the vapour barrier. It can also be used to level out minor depressions in the subfloor (max. three layers with underfloor heating). It can also be used in strips as an intermediate layer for 20 mm flooring installed floating on battens.

**3.** Cellofloor, (3 mm polyethene foam intermediate layer) (30 kg/m<sup>3</sup>), must be laid with butt-jointed edges. Cellofloor in strips is also an ideal intermediate layer for 20 mm flooring installed floating on battens. It must never be laid in more than one layer.

**4.** Kährs Tuplex, 3 mm polyethene sheeting with polystyrene granules, is a combination underlay and must be laid with the text side facing upwards and the integral 200 mm flap outwards. The flap is folded down and the next sheet is laid over it with the sheet edges butt-jointed. This provides the vapour barrier function. If Kährs Tuplex has to be joined at the short ends, a 400 mm wide strip of 0.2 mm age-resistant polyethene sheeting must be laid over the join to make it impervious. Kährs Tuplex installed in this way acts as both a vapour barrier and an intermediate layer. Tuplex must never be laid in more than one layer.

**5.** Kährs Protective Paper is laid with the film side facing down. Protective paper is used to protect the parquet against spillages and light wear after installation. Do not tape protective material to the wood floor. Greater protection must be provided if heavy items are to be moved across the floor, e.g. a refrigerator or freezer with small "wheels". Clean the floor thoroughly before laying the protective paper. Look out for grit and sand that can be pressed down through the paper. The protective paper is biodegradable and recyclable.



**Using tools and accessories**

**1.** A tapping block is used for installing boards with Woodloc® joints. Positioning the boards requires only light taps on their edges. Hold the tapping block lengthways against the edge of the board. Keeping one end in contact with the edge of the board, tap the board with the block. This applies the correct force, and the board is not damaged.

**2.** A laying wedge is used for Woodloc® installation. It is designed so that it can also be used when gluing boards to the subfloor. Used for both multi-layer parquet and Kährs Linnea.

**3.** Use a heel iron to tap the last row into place.

**4.** Kährs Adhesive for wood floors. A 1-component, polyvinyl acetate-based adhesive used for traditional joints and in special solutions with the Woodloc® joint. Must be stored out of the reach of children. Ensure good ventilation. Can be stored down to -15°C.

**5.** Use pairs of installation wedges (with “notches”) to create a flexible space between the floor and adjacent surfaces when installing floor boards. Use two or more, depending on the size of the movement joint. Remove the wedges when installation is complete.

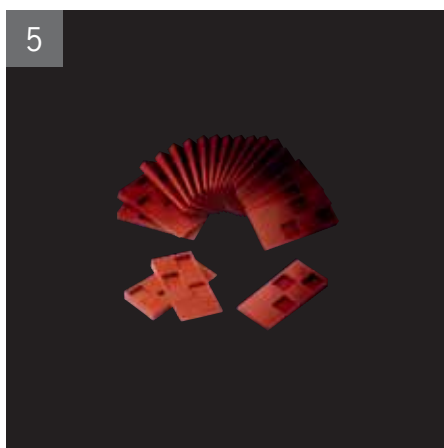

### Installation instructions for Kährs wood floors with Woodloc® joints

Floating installation on level and solid substrates Complete installation instructions are provided in every other pack Use Kährs installation tools.

#### Preparation

- If the installation requires a vapour barrier, do not forget it.
- First, calculate how many floor boards are required. If the last row is less than 30 mm wide, cut the first row, too. When installing floors with Woodloc® joints, it is easier if you start on the side with more doors. If there are doors along the short side of the room, begin each row of boards there. The boards can be installed from both left and right.
- The maximum floor width is 18 metres. If the floor is wider, contact Kährs.

**1.** Begin in one corner, and work from left to right with the long underlip facing into the room. The gap between the long side and the wall can be adjusted once three rows have been laid.

**2.** Press the next floor board in at an angle against the first, and lay it flat. Continue in the same way along the rest of the first row.

**3.** Cut the last board in the first row to the correct length, and begin the next row with the piece left over. The end joints between boards must be staggered by at least 500 mm (at least 300 mm for 1.2 m boards and 7 mm Linnea).

**4.** Press the floor board in at an angle against the board in front. Tap lightly with the block while carefully pressing the board downwards.

**5.** Push a Kährs Laying Wedge in under the end of the board already laid.

**6.** Press the short end of the next board into position at an angle, and lay the long side of the board down.

**7.** Remove the laying wedge and, using the block, tap gently on the long side while carefully pressing the board down. This will locate it more easily.

**8.** The gap between the floor and the walls can be adjusted once three rows have been laid. Place wedges between floor and the wall. Remove the wedges when floor laying is finished.

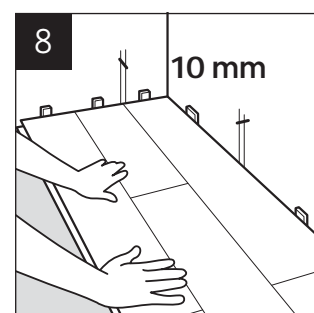
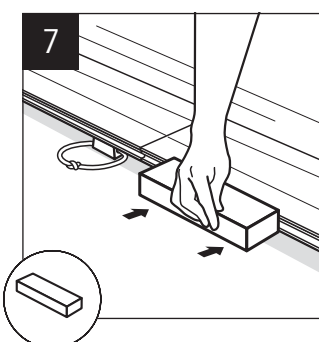
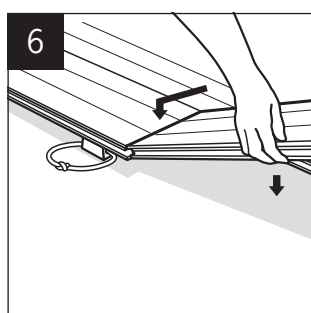
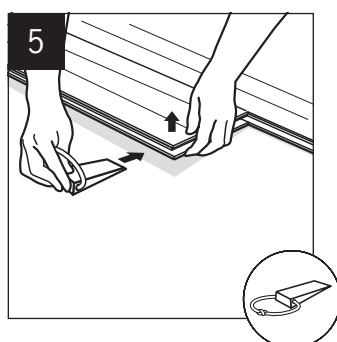
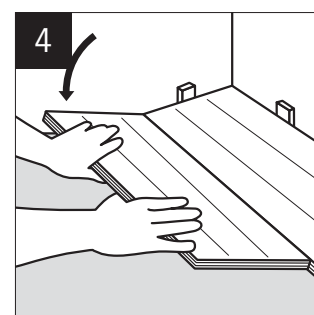
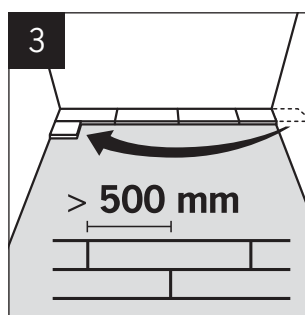
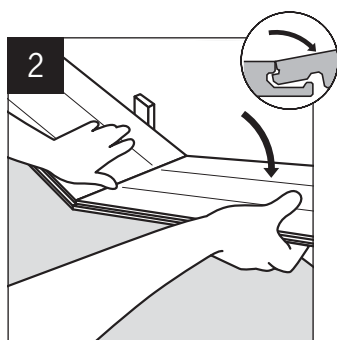
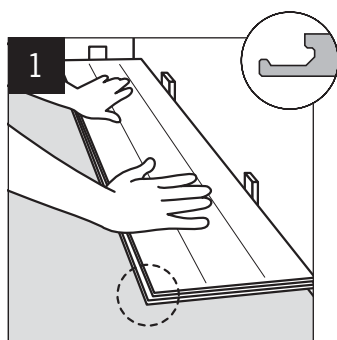

**9.** The first row sometimes requires adjustment to suit a wall that is out of true. Draw the contours of the wall on the floor boards. Then free each board in the first row by gripping its long side and pulling upwards while tapping gently against the joint. Saw along the line.

**10.** Then replace the sawn floor boards from left to right. Push the end in first, then the long side, as described in points 5-7. Insert wedges between the floor and the wall.

**11.** Drill holes in the boards for radiator pipes. The diameter of the hole must be at least 20 mm bigger than that of the pipe. Cut out as in the illustration. When the board has been fitted, glue the cut-out in position and cover the hole with a pipe collar or pipe rose.

**12.** If you need to trim a door architrave, use a floor board as a guide to get the correct height. If you need to tap the board lengthways, insert an end off-cut into the joint to protect it.

**13.** Saw the last row of boards to the correct width as follows. Rest the last board on the last but one row, offset towards the wall by about 5 mm. Using an offcut with no locking moulding, mark where

the saw cut should be made. Lay the cut board. Do the same with the next one. Fit the skirting boards. These must not press down on the floor and trap it. Use level mouldings or edge mouldings at transitions to other rooms.

**14.** If necessary, you can lay boards from any direction. This helps when laying in doorways, for example. If you cannot angle a board in under an architrave or low radiator, for example, proceed as follows: 14a. Cut away about 2/3 of the locking moulding. 14b. Glue. Push the board into position.

Woodloc® cannot be installed with ends against long sides. If you plan to do more building work in the room, remember to protect the floor with moisture-permeable material, for example, Kährs Protective Paper.

**Tip:** Sometimes floor boards have to be pushed into position (long side or short side). This applies in doorways, for example, or other difficult places where the board needs to be slid into place. When a board has to be tapped in lengthways, fit a small offcut from the end of a board into the joint. This protects the end of the board.

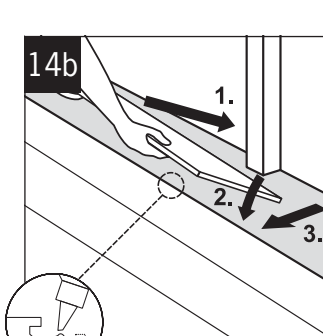
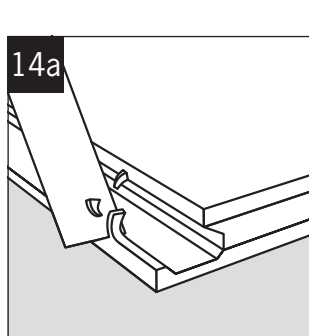
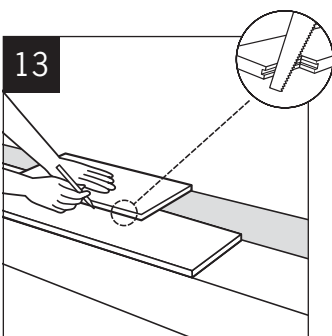
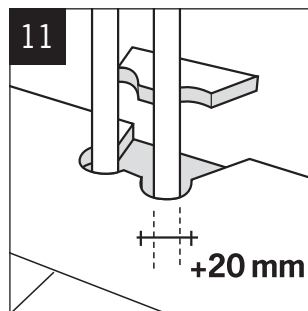
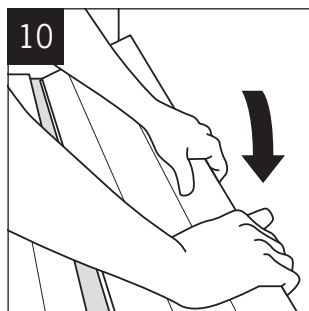
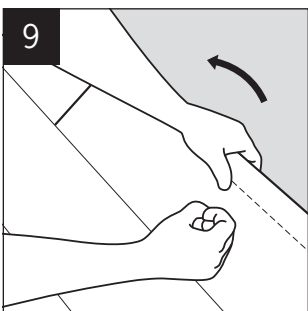

**A few problems that are easy to solve.**

**A.** Always begin each row of boards from a doorway. This makes it easier to push the prepared board under the frame. With Woodloc®, the other boards in the row can be laid from either left or right.

**B.** Lay the board as close to the frame as possible, then tap it in carefully from the short end. Protect the board with an offcut (e.g. matching short end).

**C.** If you are unable to angle the board in at a door architrave, plane off 2/3 of the locking moulding. This allows you to tap the board into place. Apply adhesive to the underlip to avoid weakening the joint.

**D.** When installing under reveals it is often easiest to fit these boards before the return wall board is laid.

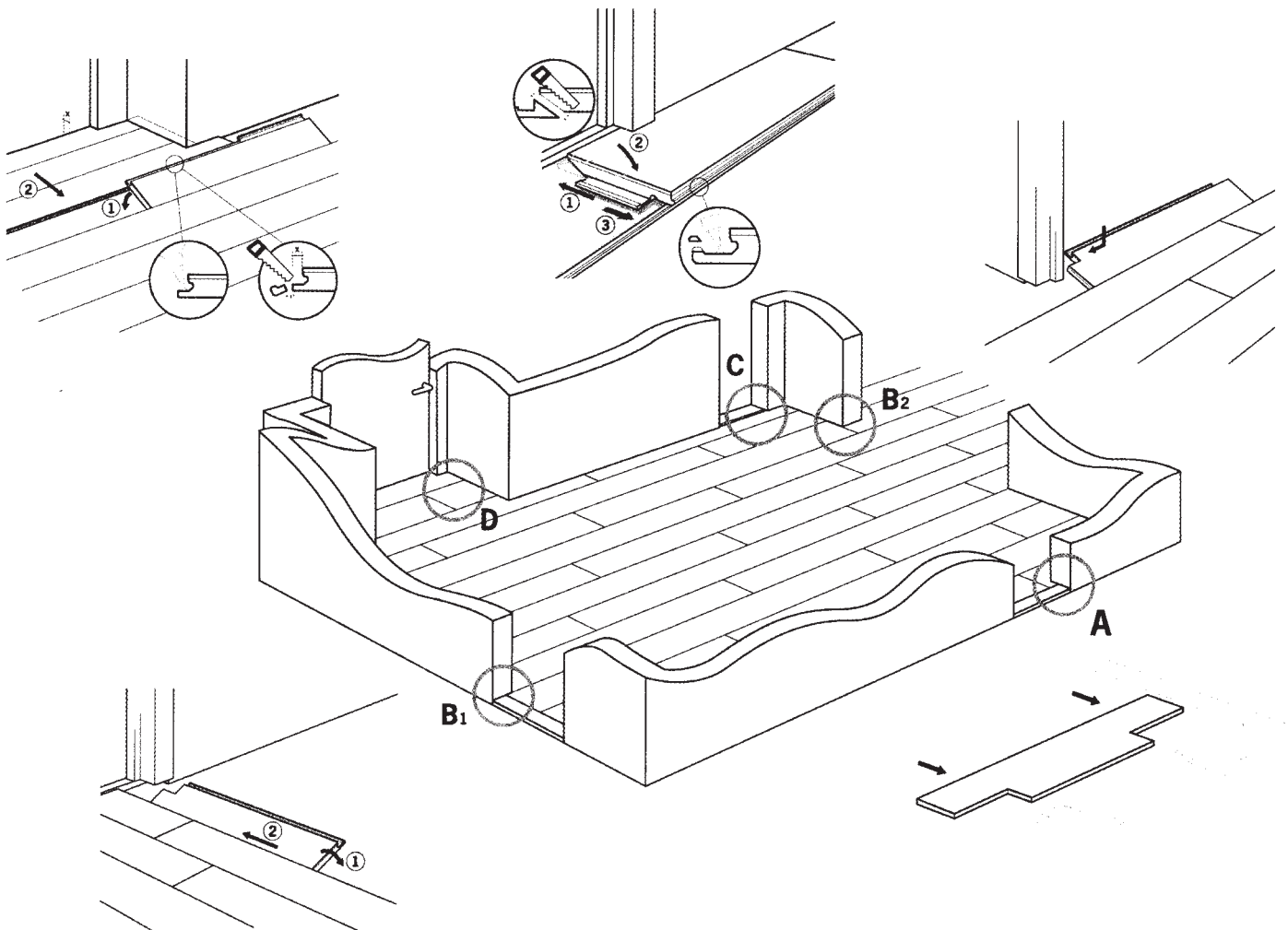

**Installation instructions for Kährs Activity Floor 30 mm; floating on level and solid substrates**

Complete installation instructions are provided in every other pack. Use Kährs installation tools.

**Preparation**

- If the installation requires a vapour barrier, do not forget it.
- First, calculate how many floor boards are required. If the last row is less than 30 mm wide, cut the first row, too. When installing floors with Woodloc® joints, it is easier if you start on the long side with more doors. If there are doors along the short side of the room, begin each row of boards there. The boards can be installed from both left and right.
- The maximum floor width is 18 metres. If the floor is wider, contact Kährs.

**1.** Begin in one corner, and work from left to right with the long underlip facing into the room. The gap between the long side and the wall can be adjusted once three rows have been laid.

**2.** Press the next floor board in at an angle against the first, and lay it flat. Continue in the same way along the rest of the first row. Use a string line to check that the first line of boards is straight.

**3.** Cut the last board in the first row to the correct length, and begin the next row with the piece left over. The end joints between boards must be staggered by at least 500 mm.

**4.** Press the floor board in at an angle against the board in front. Tap lightly with the block while carefully pressing the board downwards.

**5.** Push a Kährs Laying Wedge in under the end of the board already laid.

**6.** Press the short end of the next board into position at an angle, and lay the long side of the board down.

**7.** Remove the laying wedge and, using the block, tap gently on the long side while carefully pressing the board down. This will locate it more easily.

**8.** The first row sometimes requires adjustment to suit a wall that is out of true. Draw the contours of the wall on the floor boards. Saw along the line.

**9.** Drill holes in the boards for radiator pipes. Holes must be at least twice the size of the calculated movement joint at the wall plus the pipe diameter. Example: If the floor is 10 m wide, the hole will be  $10 \times 1.5 = 15$  mm. This means  $2 \times 15 = 30$  mm bigger than the pipe. Cut out as in the illustration. When the board has been fitted, glue the cut-out in position and cover the hole with a pipe collar.

**10.** If you need to trim a door architrave, use a floor board as a guide to get the correct height. If you need to tap the board lengthways, insert an end off-cut into the joint to protect it.

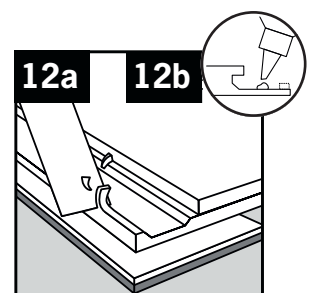
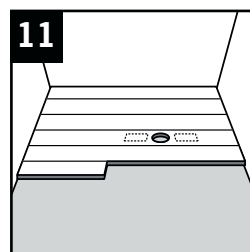
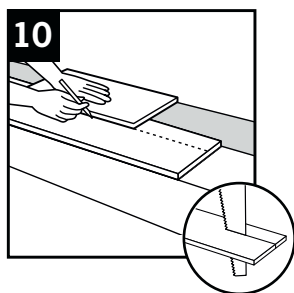
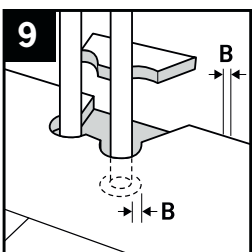
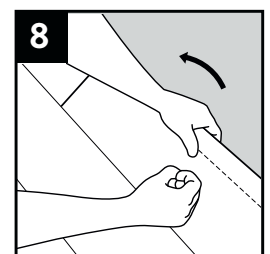
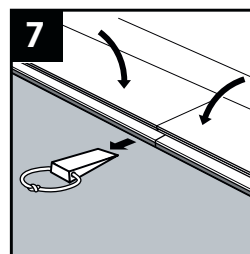
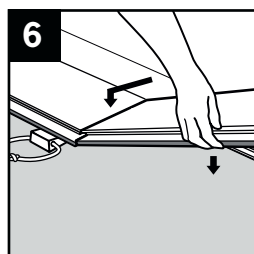
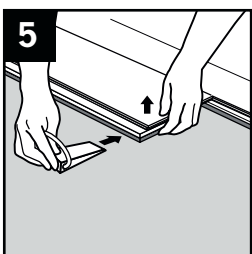
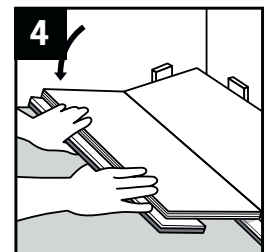
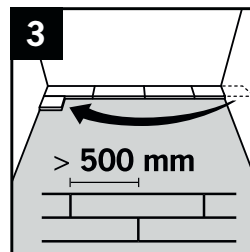
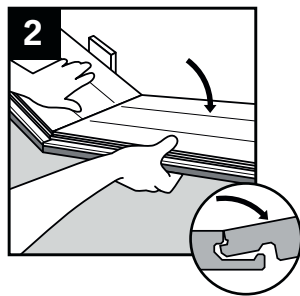
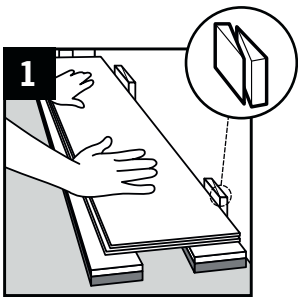

**11.** Skirting boards must not be nailed to the floor or pressed down so that the floor is trapped. All connection rails must be fixed in the concrete so as not to prevent the wood floor's natural movements.

**12.** If necessary, you can lay boards from any direction. If you cannot angle a board in under an architrave or low radiator, for example, proceed as follows: 12a. Cut away 2/3 of the locking edge. 12 b. Glue. Tap the board into position with a heel iron.

If you plan to do more building work in the room, remember to protect the floor with moisture-permeable material.

#### Finishing off:

- **Fixing fittings:** Fixings for goalposts and other equipment must be anchored in the concrete floor. The tops of fixings must be flush with or slightly lower than the subfloor. The easiest way to make cut-outs for fixing apparatus and attaching fittings in the wood floor is to use a hole cutter.
- **Line marking:** Before marking out lines, the surface to be painted must be cleaned thoroughly in accordance with the paint manufacturer's instructions. Lines should be marked by specially trained personnel.
- **Re-lacquering floors that have line markings:** Re-lacquering can be carried out 24 hours after line painting is complete. Remember that the floor may need cleaning again to remove dust and dirt. The temperature of the room and the lacquer must not be lower than 13°C during lacquering. Spread the lacquer using a roller, applicator or lacquer brush.

#### Installation instructions for Kährs 15 mm on 150 kPa expanded foam, floating, in domestic rooms Insulation with EPS

The foam sheets must comply with min. Group M, compression strength =150 kPa (density 30 kg/m<sup>3</sup>) in accordance with SSEN13163. It is important that they are designed for this application and that they comply with the requirements for thickness tolerance and density. The density must be within ±10%.

To avoid undesirable flexing of the finished floor, the thickness tolerance of the sheets must be ±0.5 mm. For the same reason, bowed sheets must not be used.

Lay the foam sheets at right angles to the direction that the floor will be laid and stagger them so that there are no continuous joints running lengthways along the boards. The entire subfloor must be covered with foam sheets in such a way that the boards are supported. Special attention must be given to pipe runs and door openings, etc. Reinforcement with timber battens may be required in some places. Follow the foam manufacturer's instructions. To prevent indentations, the foam sheets must be protected if they are to be walked on before the floor is installed.

#### Intermediate layer

An intermediate layer must be installed between the foam and the wood floor to avoid squeaks.

#### Installation instructions for Kährs Linnea on 150 kPa expanded foam, floating on load-distributing chipboard sheets in domestic rooms

##### General

A load-distributing layer of non tongue and groove chipboard (at least 10 mm) or 6 mm tongue and groove fibreboard must be used.

##### Insulation with EPS

The foam sheets must comply with min. Group M, compression strength =150 kPa (density 30 kg/m<sup>3</sup>), in accordance with SSEN13163. It is important that they are designed for this application and that they comply with the requirements for thickness tolerance and density. The density must be within ±10%.

To avoid undesirable flexing of the finished floor, the thickness tolerance of the sheets must be ±0.5 mm. For the same reason, bowed sheets must not be used.

Lay the foam sheets at right angles to the direction that the floor will be laid, and stagger them so that there are no continuous joints running lengthways along the boards. The entire subfloor must be covered with foam sheets in such a way that the boards are supported. Special attention must be given to pipe runs and door openings, etc. Reinforcement with timber battens may be required in some places. Follow the foam manufacturer's instructions. To prevent indentations, the foam sheets must be protected if they are to be walked on before the floor is installed.

##### Intermediate layer

An intermediate layer must be installed between the foam and the wood floor to avoid squeaks.

#### Installation instructions for Kährs wood floor on 250 kPa expanded foam, floating, in public environments

The foam sheets must comply with at least Group T, compression strength =250 kPa (density 40 kg/m<sup>3</sup>), in accordance with SSEN13163. It is important that they are designed for this application and that they comply with the requirements for thickness tolerance and density. The density must be within ±10%.

To avoid undesirable flexing of the finished floor, the thickness tolerance of the sheets must be ±0.5 mm. For the same reason, bowed sheets must not be used.

Lay the foam sheets at right angles to the direction that the floor will be laid, and stagger them so that there are no continuous joints running lengthways along the boards. The entire subfloor must be covered with foam sheets in such a way that the boards are supported. Special attention must be given to pipe runs and door openings, etc. Reinforcement with timber battens may be required in some places. Follow the foam manufacturer's instructions. To prevent indentations, the foam sheets must be protected if they are to be walked on before the floor is installed.

## Fixing instructions for wood floor accessories

### Mouldings and trims

Used to cover movement joints, expansion joints, etc. Kährs has mouldings for the majority of wood species. You can find details of our wood mouldings and aluminium trims on [www.kahrs.com](http://www.kahrs.com).

### Note the requirement for movement joints between wood floor and level-, edge- and T-mouldings and Linnea surface-mounted nosings.

- Level mouldings are used for transitions to a lower level.
- Transition mouldings are used to cover expansion joints, for example.
- Edge mouldings are used to cover movement joints at balcony doors, for example.

### Fixing mouldings and trims

Do not press the moulding or trim down too hard, otherwise the floor may become trapped or start to creak. For the same reason, therefore, mouldings and trims should not be glued, screwed or nailed into or through the wood floor.

### Flexi moulding – the skirting board that can be bent.

Flexi moulding is particularly suitable for use around pillars, for example, with a minimum diameter of 200 mm. If the Flexi moulding is not sufficiently flexible at first, it can be moistened with a sponge and water. Put the moulding back into the plastic bag supplied and close it. Allow the moisture to work overnight. Repeat the treatment if the moulding is still not sufficiently flexible. Measure the length,

and shape the moulding as required. Note that there will be some shrinkage as the wood dries. Allow to dry in the shaped position for at least 48 hours before fixing and applying the surface treatment.

The procedure can be rationalised if a large number of mouldings are involved.

- Measure the circumference of the pillar.
- Add the allowance for contraction and cut the mouldings to half the circumference.
- Moisten the mouldings with a sponge and water, put them back into the plastic bag supplied and close it.
- Allow the moisture to work overnight. Repeat the treatment if the moulding is still not sufficiently flexible.
- Secure it around the pillar with a strap until the moulding has dried and contracted (48 hours).
- Fix it to the pillar (with plugs and screws).
- The moulding can be reshaped at any time by moistening it again (provided no surface treatment has been applied).

### Aluminium trims

The trim system comprises a base trim and various types of cover trims. These can be used for wood floors 7–16 mm thick. The base trim is threaded for the special screws (supplied). Fix the base trim to the subfloor using the screws supplied. Drill 5 mm holes for concrete floors. Drive in the plastic plugs supplied and fix the trim using the cross-headed screws (Poqidrive 1).

### Fixing veneered skirtings

To achieve a neat juncture with (e.g.) architraves, mitre the moulding.

**Fixing instructions for Kährs nosings**

A nosing in a different species is an effective way of indicating where stairs begin and end.

**Option A:**

When installing a floor from the wall to the stairs.

**Option B:**

When installing a floor from the stairs to the wall. Screws are used for both options.

**OPTION A**

**A1**

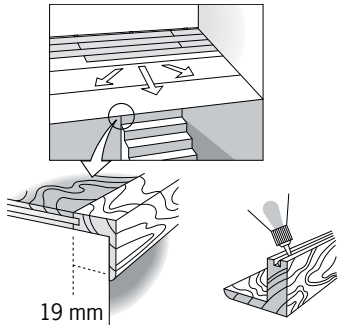

**A2**

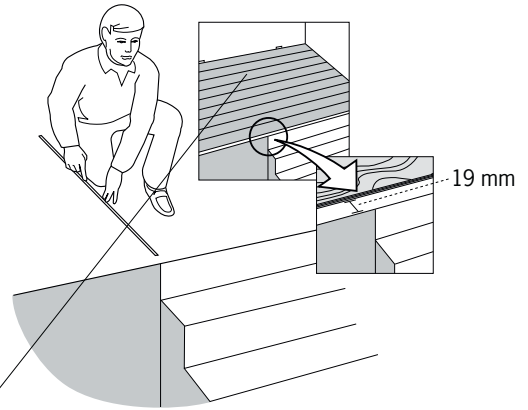

**A3**

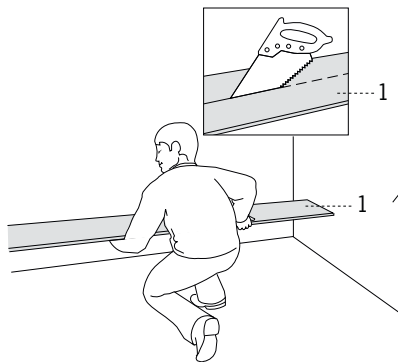

**A4**

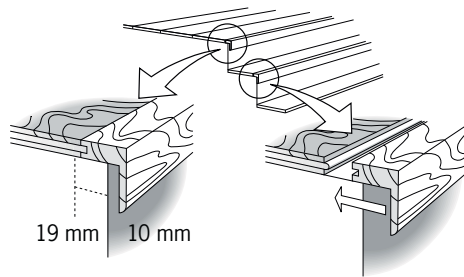

**OPTION B**

**B1**

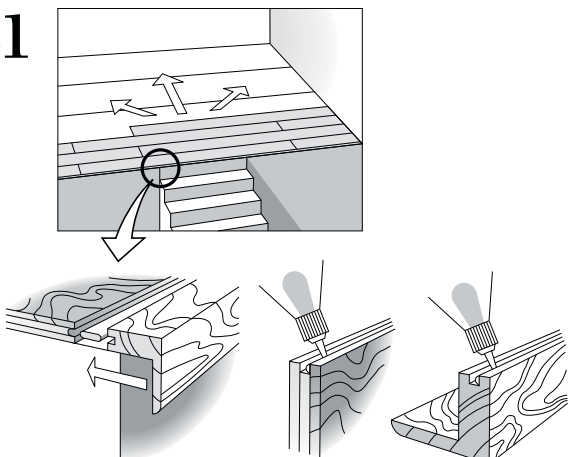

**1.**

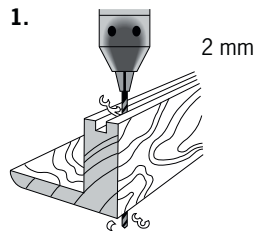

**2.**

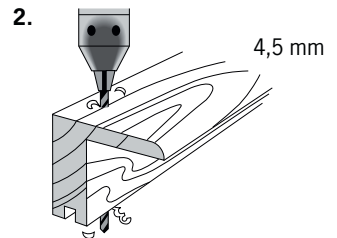

**3.**

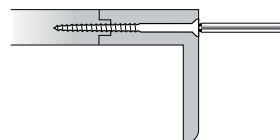

### Nosings for Woodloc®

If nosing with Woodloc® is to be used, plan the installation so that the final board joint is in line with the edge of the top step to allow the nosing to be hooked into place. Adjust the position to create a movement joint. Glue the nosing where it adjoins the flat underlip. If this installation method is not possible, use nosings for traditional joints.

Nosings for Woodloc® are available for both 15 mm multi-layer boards and Linnea.

### Nosings for traditional joints

Used when a Woodloc® nosing is not suitable. If the floor ends at right angles to the stair, or if the method of installation above is not possible, it may be necessary to cut the board and make a new groove in it. Cut the groove with router using a 4.5 mm panel bit. Adjust the height carefully.

Available for 15 mm multi-layer boards. Spare tongues are included.



**Instructions for supplementary products**

**1.** Pipe collars are used to conceal movement joints at radiator pipes. The halves of the pipe collars are glued together around the pipe (see illustration). Size Ø 50 mm for 18 mm pipe.

**2.** Pipe roses are used to conceal movement joints round radiator pipes, etc. Measure where the hole should be and drill a hole for the pipe using a bit only slightly bigger than the pipe. Use wood adhesive to glue the rosette halves together around the pipe (see illustration). Size 50 x 110 mm.

**3.** Use a hammer to fit knock-in furniture pads. These are recommended for wooden legs and heavy furniture because they sit better.

Use self-adhesive furniture pads where knock-in pads are unsuitable. Furniture pads wear out and need replacing regularly.

**4.** Woodfiller is used to fill small chips, etc. If a lot of filler is required, filling may need to be repeated because the filler may slump. Always use Touch-up Lacquer or Touch-up Oil depending on

the floor's original surface treatment. Woodfiller is available in 8 different colours to suit the wood species. Woodfiller can withstand freezing conditions. If necessary, Woodfiller can be made softer by warming it in water for a while. Use it at room temperature. Mix with water if it has dried in the can.

**5.** Use Touch-up Lacquer (water-based) on UV-lacquered floors to repair minor damage and small scratches, and to make good repairs using Woodfiller. It has the same gloss value as satin lacquer and matt lacquer (30° and 10° Gardner, respectively). Glass bottle (30 ml) with brush. Protect from frost. Shelf-life at least one year from date of manufacture.

**6.** Touch-up Oil is used for repairing minor damage and small scratches on oiled floors and to make good repairs using Woodfiller. It has the same gloss value as UV oil (10° Gardner). Glass bottle (30 ml) with brush.

**7.** Kährs Repair Kit is a hot-melt wax used for small chips, etc. The kit contains heater, hard wax, spatula, felt-tip pens, Touch-up Lacquers and Touch-up Oils, plus instructions.

